

Model Predictive Control for Power Systems and Power Electronic Applications

Alejandro Garcés

Universidad Tecnológica de Pereira

alejandro.garces@utp.edu.co

1st LATAM meeting on green ammonia and Power-to-X
January 2024

Contents

Motivation: control in power systems

Model predictive control

Local controls

Supervisory controls

Final remarks

The power system

19.7 GW
1310 kWh per capital
60 – 80% hydro



Inverter-baser resources (IBRs)

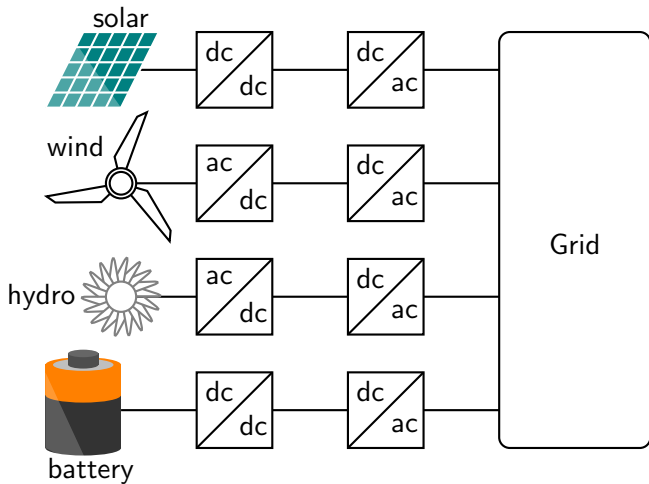

Hydrogen systems

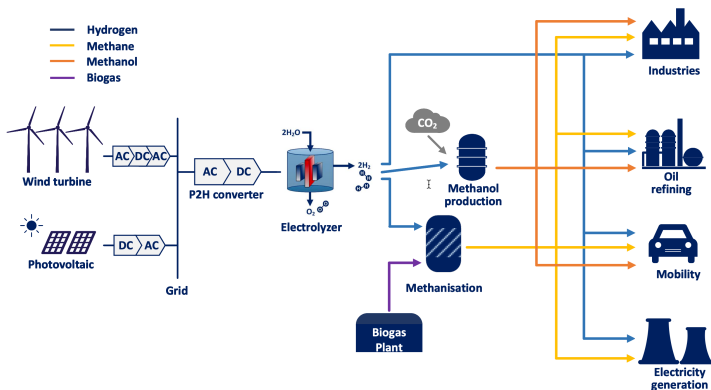
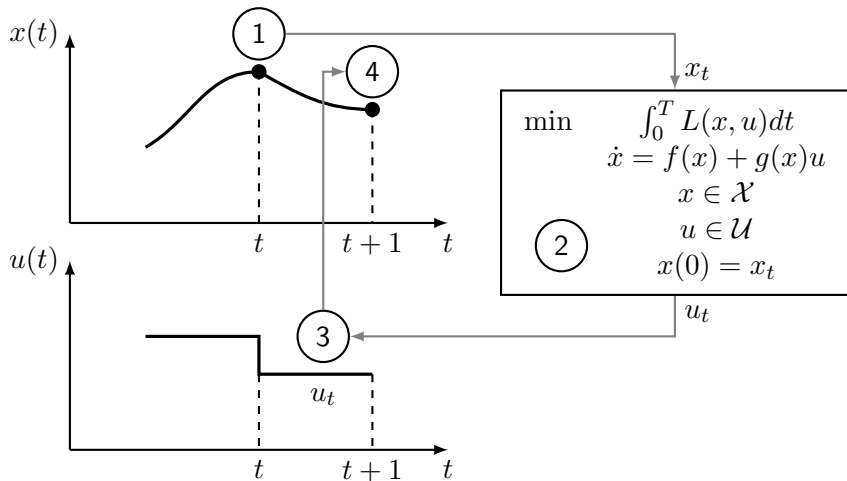

Image taken from: Chen, M.; Chou, S.-F.; Blaabjerg, F.; Davari, P. Overview of Power Electronic Converter Topologies Enabling Large-Scale Hydrogen Production via Water Electrolysis. Appl. Sci. 2022, 12, 1906. <https://doi.org/10.3390/app12041906>

Challenges

- Power loss on the power-electronic devices
- Scale and modularity
- Robustness and reliability
- **Efficiency**
- **Stability**

Model predictive control



The optimal control problem (OCP)

$$\begin{aligned} \min \int_0^T L(x, u) dt \\ \dot{x} &= f(x) + g(x)u \\ x &\in \mathcal{X} \\ u &\in \mathcal{U} \\ x(0) &= x_t \end{aligned}$$

Remarks:

- Optimality does not imply stability
- The OCP must be solved in real-time
- The OCP may be non-linear

MPC in power systems and power electronics

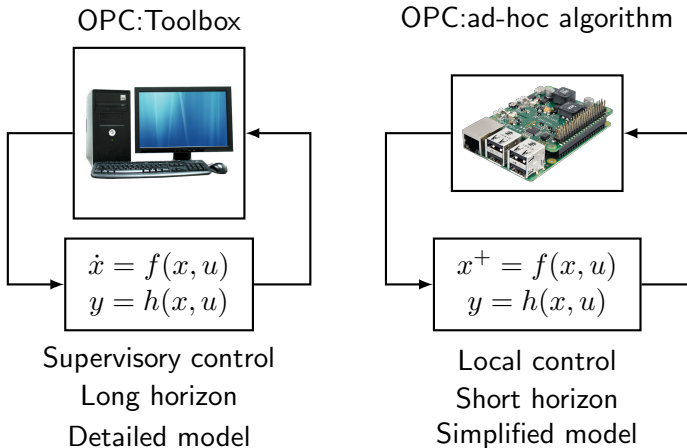

MPC in power systems and power electronics

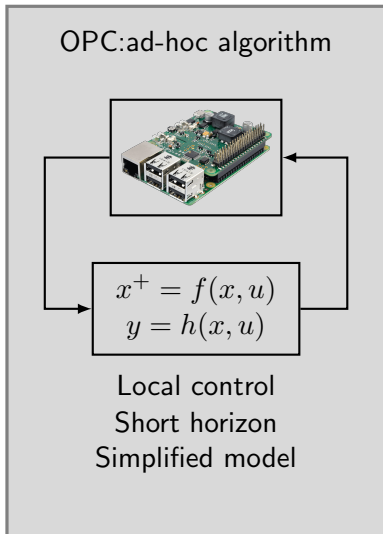
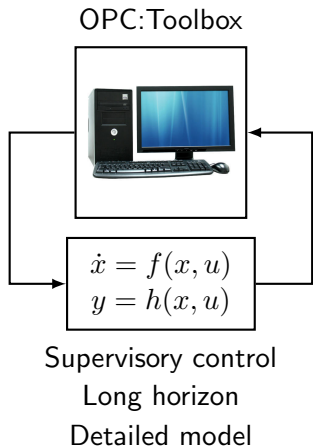

Modelling power electronic converters (DC/DC)

$$x^+ = Ax + u\psi(x),$$
$$\psi(x) = Bx + b$$

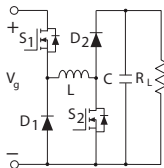
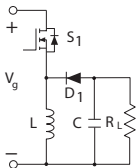
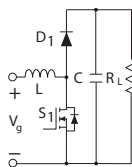
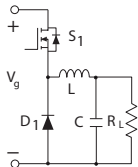

MPC in power electronics

Finite-control set

$$\begin{aligned} \min L(x, u) \\ x^+ &= f(x, u) \\ u &\in \{0, 1\} \end{aligned}$$

Continuous-control set

$$\begin{aligned} \min L(x, u) \\ x^+ &= f(x, u) \\ u &\in [0, 1] \end{aligned}$$

Proposed OCP

$$\begin{aligned} \min \quad & \frac{1}{2} \|x^+\|_Q^2 + \frac{1}{2} \rho u^2 \\ & x^+ = Ax + u\psi(x) \\ & \psi(x) = Bx + b \\ & u_t \in \mathcal{U}, \end{aligned}$$

Karush-Kuhn-Tucker conditions:

$$u_t = \frac{-(Ax_t)^\top Q\psi(x_t) + \gamma_0 - \gamma_1}{\rho + \psi(x_t)^\top Q\psi(x_t)}.$$

$$\gamma_0(\underline{u} - u_t) = 0$$

$$\gamma_1(u_t - \bar{u}) = 0$$

$$\gamma_0, \gamma_1 \geq 0$$

$$\underline{u} \leq u_t \leq \bar{u}$$

Passivity in discrete time

Definition

$$\begin{aligned}x^+ &= f(x, u) \\ y &= h(x, u)\end{aligned}\tag{1}$$

A system of the form (1) is said to be passive if there exists a nonnegative $V(x) : \mathbb{R}^n \rightarrow \mathbb{R}$ with $V(0) = 0$, called the storage function, such that the dissipation inequality $V(x^+) - V(x) \leq y^\top u$ holds



Lin W, Byrnes C. KYP lemma, state feedback and dynamic output feedback in discrete-time bilinear systems. *Systems and Control Letters* 1994; :127–136

Our main result

$$\begin{aligned} \min \quad & \frac{1}{2} \|x^+\|_Q^2 + \frac{1}{2} \rho u^2 \\ & x^+ = Ax + u\psi(x) \\ & \psi(x) = Bx + b \\ & u_t \in \mathcal{U}, \end{aligned}$$

Theorem

The proposed MPC is asymptotically stable



A. Garcés-Ruiz, S. Riffo, C. González-Castaño and C. Restrepo, "Model Predictive Control with Stability Guarantee for Second-Order DC/DC Converters," in IEEE Transactions on Industrial Electronics, doi: 10.1109/TIE.2023.3283706.

Simulation results

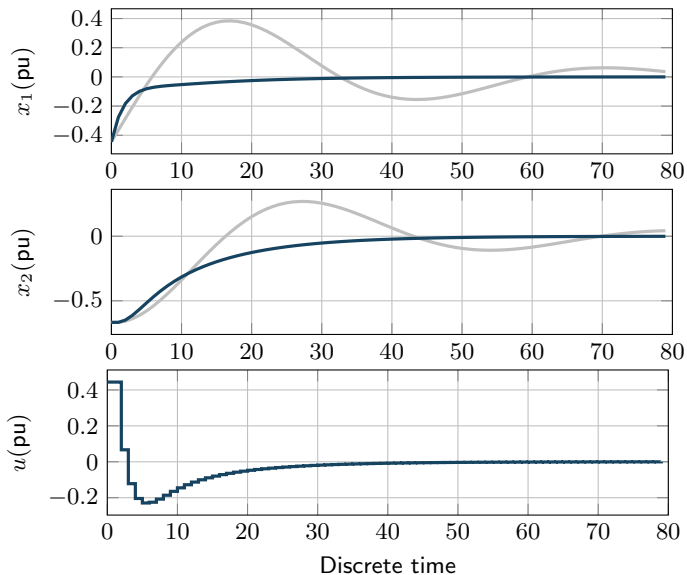

Experimental results

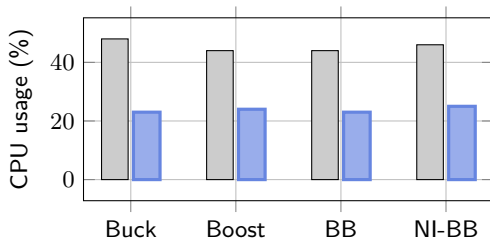
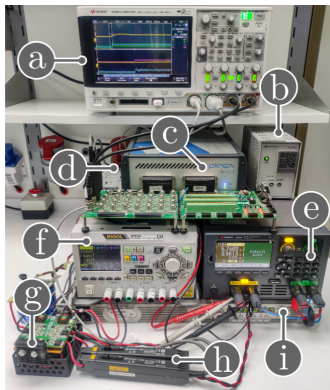

A. Garcés-Ruiz, S. Riffo, C. González-Castaño and C. Restrepo, "Model Predictive Control with Stability Guarantee for Second-Order DC/DC Converters," in IEEE Transactions on Industrial Electronics, doi: 10.1109/TIE.2023.3283706.

Versatile buck-boost converter

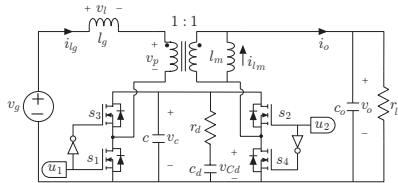
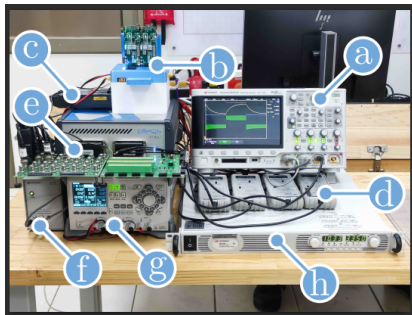

PWM-VSC (SINTEF-Smart Grid Lab)



MPC in power systems and power electronics

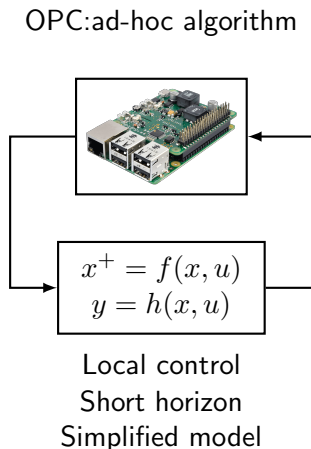
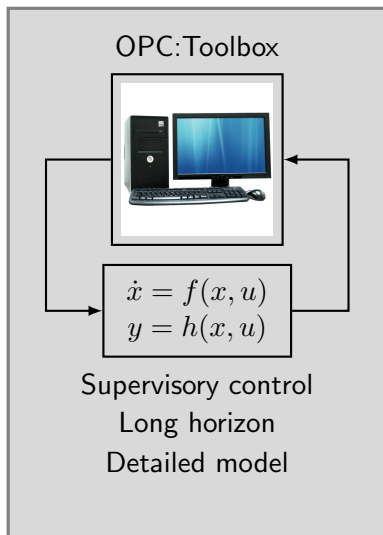

Stability in MPC

$$\begin{aligned} \min \quad & \int_0^T L(x, u) dt + V(x_T) \\ & \dot{x} = f(x, u) \\ & x \in \mathcal{X} \\ & u \in \mathcal{U} \end{aligned}$$

Stability can be ensured in MPC by

- Imposing long horizons
- Stability constraints
- Terminal constraints
- Penalization in the final step

DC Microgrid (Tecnalia)



Set-up red DC

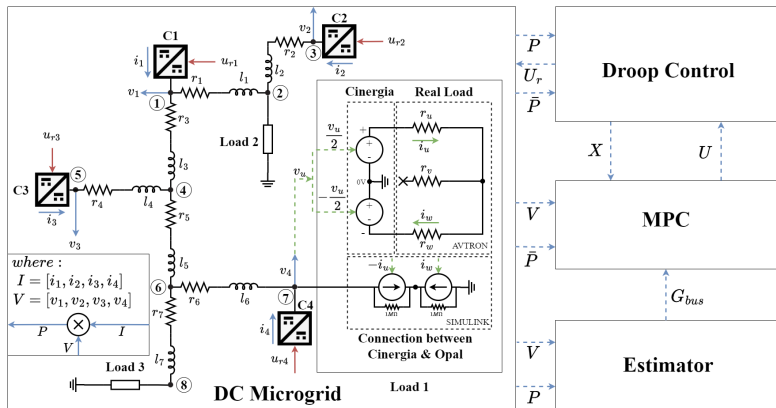

Final remarks

- Passivity is a key feature of model-predictive control in power systems
- Main strategy: optimize performance, maintaining structural properties of the physical system.
- Practical implementation is important: the control must be simple.
- MPC may be a suitable strategy for supervisory controls in hydrogen applications.

Thanks a lot!

alejandro.garces@utp.edu.co